

PHYS 170 Section 101
Lecture 14
October 5, 2018

OCT 5—ANNOUNCEMENTS

- This week's homework assignment (the one that will be released this evening) is due Monday, October 15, 11:59 PM
- Reminder: Review sessions, next Tuesday, October 9, at regular tutorial times, regular tutorial locations

Lecture Outline/Learning Goals

- Sample three-dimensional equilibrium problem #2
- What happens if there are fewer than 6 unknowns in a three-dimensional equilibrium problem?
- Sample three-dimensional equilibrium problem #3

Problem 5-76 (page 255, 12th edition)

The member is supported by a pin at A and a cable BC . The load at D is 300 lb.

(1) Determine the x , y , z components of reaction at A and the tension in the cable BC .

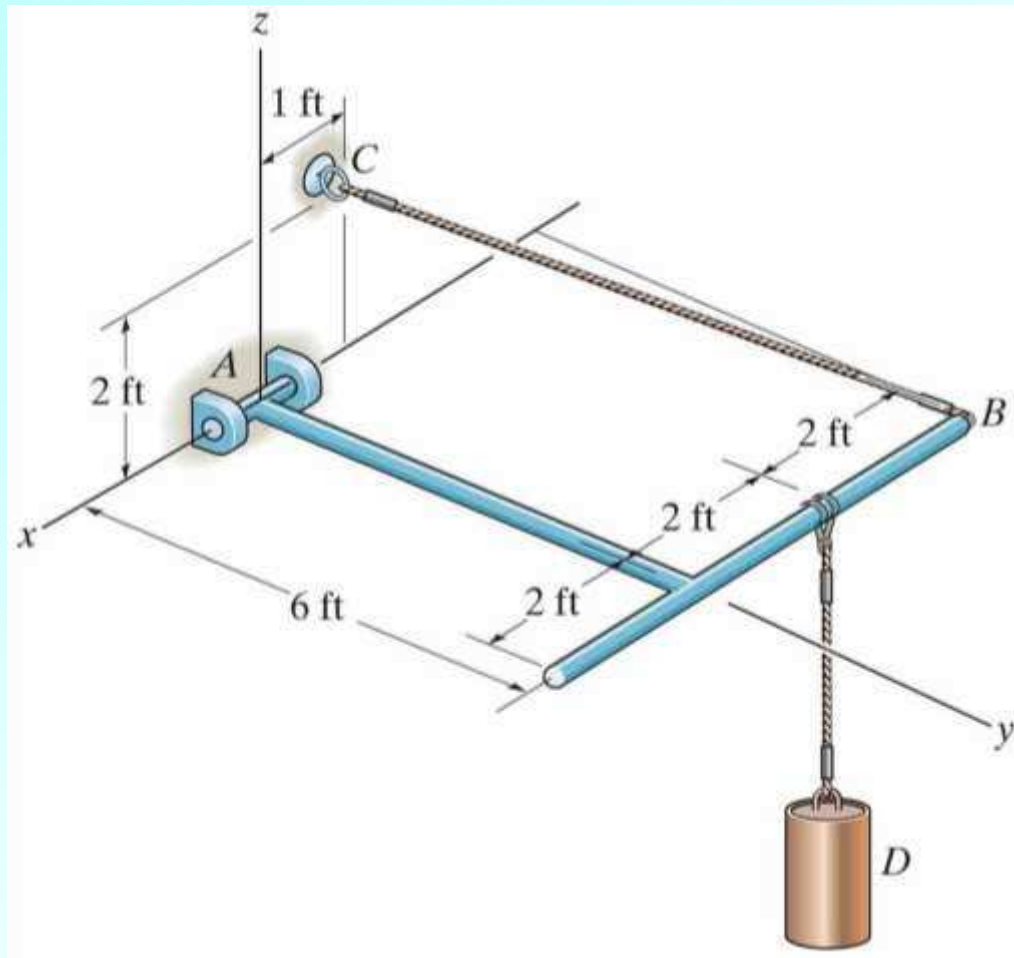

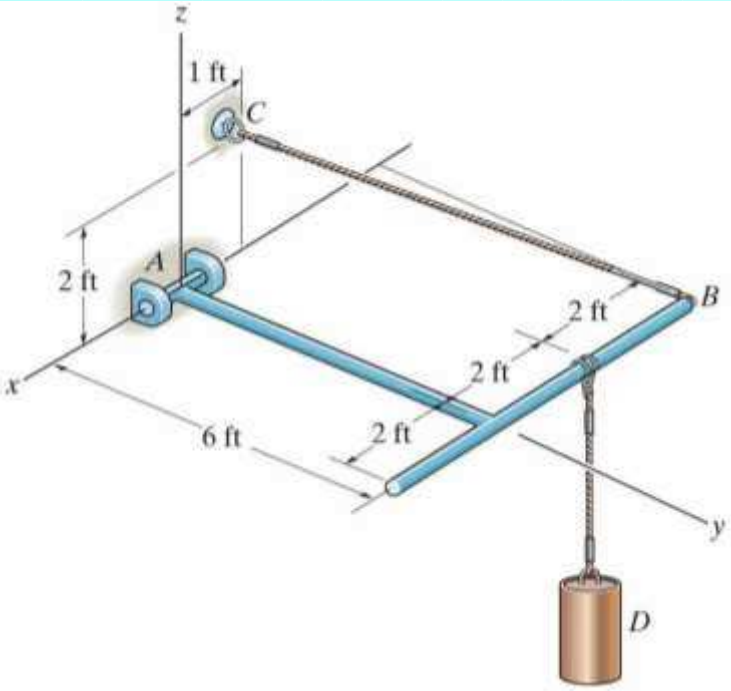

Note that moment components are developed by the pin on the rod to prevent rotation about the y and z axes.

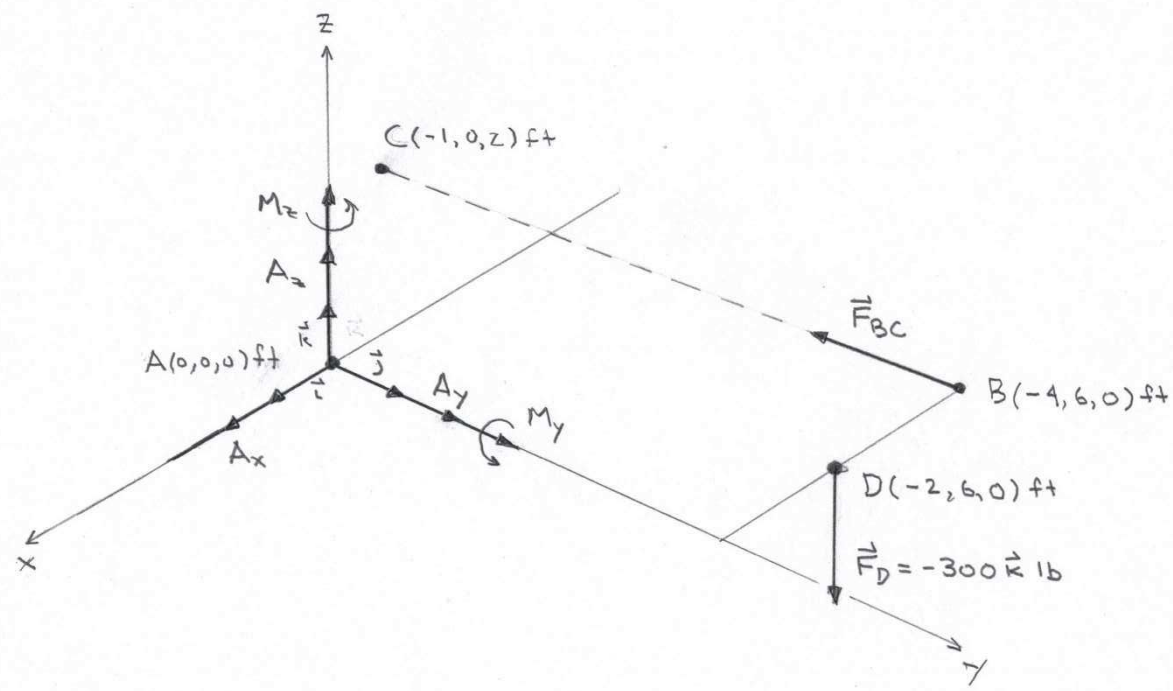

Free Body Diagram of Member

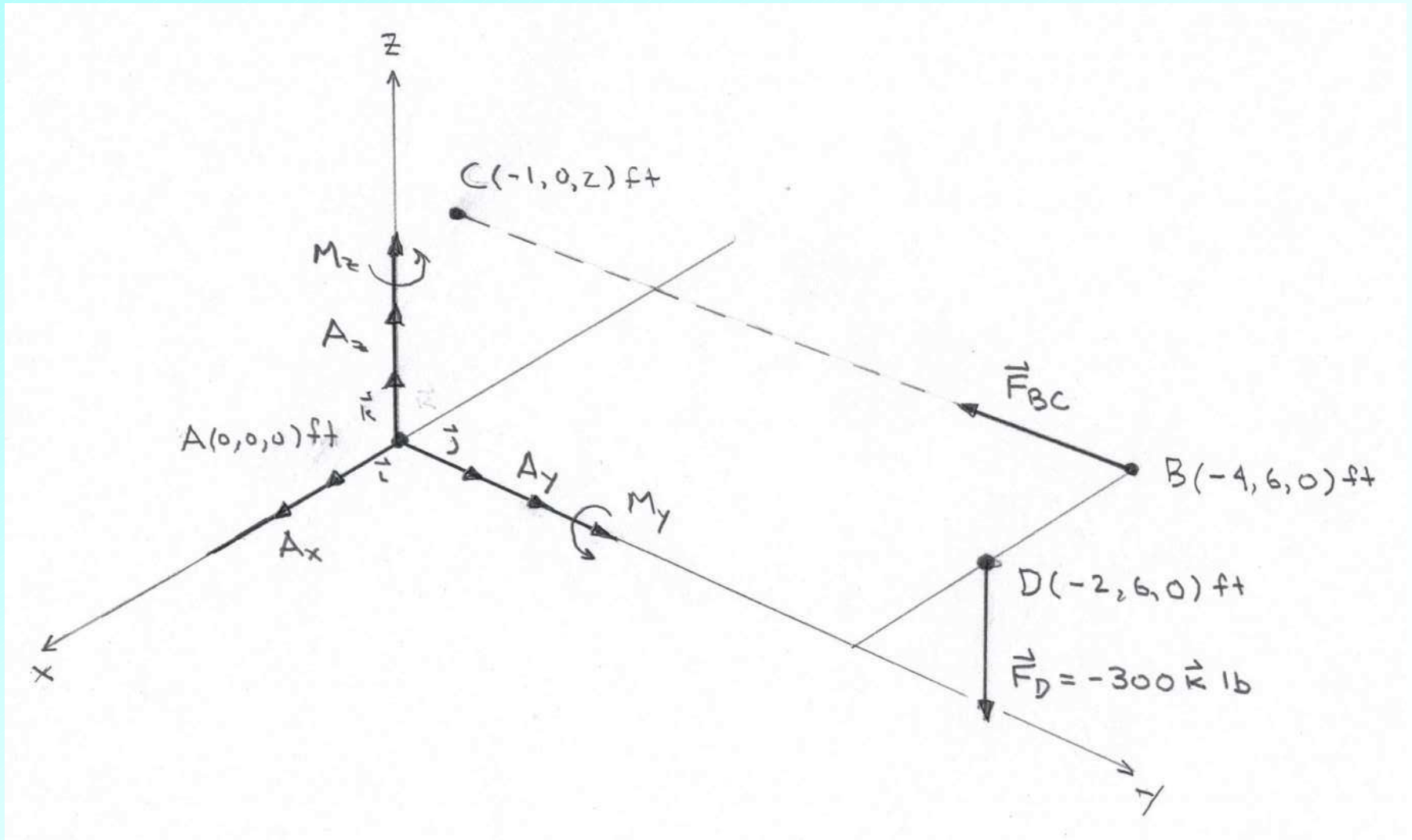

Coordinates (suppressing units)

$$A(0, 0, 0)$$

$$B(-4, 6, 0)$$

$$C(-1, 0, 2)$$

$$D(-2, 6, 0)$$

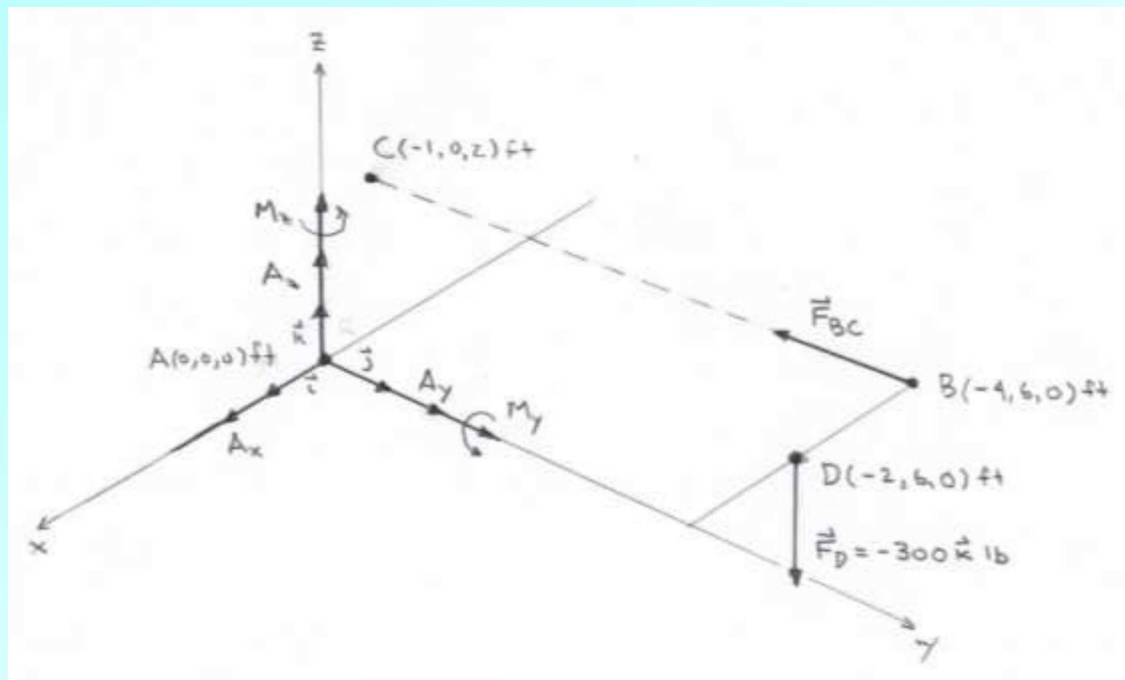

Forces and couple moment (suppressing units)

Note that there are 6 unknown reaction components, which, again, is the maximum for which we can solve using the equations of equilibrium.

$$\vec{F}_A = A_x \vec{i} + A_y \vec{j} + A_z \vec{k}$$

$$\vec{M}_A = M_y \vec{j} + M_z \vec{k}$$

$$\vec{F}_{BC} = (3\vec{i} - 6\vec{j} + 2\vec{k})X$$

$$X = F_{BC} / \sqrt{3^2 + 6^2 + 2^2}$$

$$\vec{F}_D = -300\vec{k}$$

Cartesian component force equations of equilibrium

$$\sum F_x = 0: \quad A_x + 3X = 0$$

$$\sum F_y = 0: \quad A_y - 6X = 0$$

$$\sum F_z = 0: \quad A_z + 2X - 300 = 0$$

$$\text{where } X = F_{BC} / \sqrt{3^2 + 6^2 + 2^2}$$

Vector moment equation of equilibrium at point A (force components A_x , A_y , A_z do not contribute)

$$\begin{aligned} (\vec{M}_R)_A &= \sum \vec{M} + \sum (\vec{r} \times \vec{F}) = \vec{M}_A + \vec{r}_{AC} \times \vec{F}_{BC} + \vec{r}_{AD} \times \vec{F}_D \\ &= M_y \vec{j} + M_z \vec{k} + \begin{vmatrix} \vec{i} & \vec{j} & \vec{k} \\ -1 & 0 & 2 \\ 3 & -6 & 2 \end{vmatrix} X + \begin{vmatrix} \vec{i} & \vec{j} & \vec{k} \\ -2 & 6 & 0 \\ 0 & 0 & -300 \end{vmatrix} \end{aligned}$$

Cartesian component moment equations of equilibrium

$$\sum M_x = 0: \quad 12X - 1800 = 0$$

$$\sum M_y = 0: \quad M_y + 8X - 600 = 0$$

$$\sum M_z = 0: \quad M_z + 6X = 0$$

Cartesian component equations of equilibrium

$$A_x + 3X = 0$$

$$A_y - 6X = 0$$

$$A_z + 2X = 300$$

$$12X = 1800$$

$$M_y + 8X = 600$$

$$M_z + 6X = 0$$

Solve by substitution (e.g. solve in succession X , then other 5 unknowns in any order),

use $F_{BC} = \sqrt{3^2 + 6^2 + 2^2} X = 7X$ and restore units (1 kip = 1000 lb)

$$A_x = -450 \text{ lb}$$

$$A_y = 900 \text{ lb}$$

$$A_z = 0$$

$$M_y = -600 \text{ lb ft}$$

$$M_z = -900 \text{ lb ft}$$

$$F_{BC} = 1.05 \text{ kip}$$

The negative signs indicate that the forces are directed in the sense opposite to what was assumed, that is, along the negative coordinate axes.

What Happens if there are Fewer than 6 Unknowns?

- In instances where there are fewer than 6 unknowns in a free body diagram for a three dimensional problem there may still be a solution of the equations of equilibrium
- **EXAMPLES**
 - Could have 5 unknowns, all of which are force components, and all of which have lines of action that intersect, or are parallel to, one of the coordinate axes: in this case, the corresponding scalar moment equation governing moments about that axis will be automatically satisfied, leaving 5 equations to constrain the 5 unknowns (**next Homework**)
 - Similarly, could have 4 unknowns, all of which are force components, but geometry of setup could be such that two of the moment equations are automatically satisfied. Would then have 4 equations left to constrain the 4 unknowns

What Happens if there are Fewer than 6 Unknowns?

- **You can generally expect to be given problems that *will* have a solution** (i.e. with same number of unknowns as equations that are not automatically satisfied)
- **Should note that real life will not always be as kind!!**
- See Sec. 5.7 (self study) for a discussion of additional issues that arise when the number of equations and unknowns are mismatched, or when there are the right number of unknowns, but the body is **improperly constrained**
 - **Improperly constrained** rigid bodies can often develop **instabilities** (small departures from equilibrium “run away” rather than being “damped out”)

Problem 5-78 (page 267, 14th edition)

The bent rod is supported at A , B , and C by smooth journal bearings. The bearings are in proper alignment and only exert force reactions on the rod. The rod is subjected to forces as shown where $F_1 = 300$ lb and $F_2 = 250$ lb. The weight of the rod may be neglected.

(1) Determine the x , y , z components of reaction at the bearings.

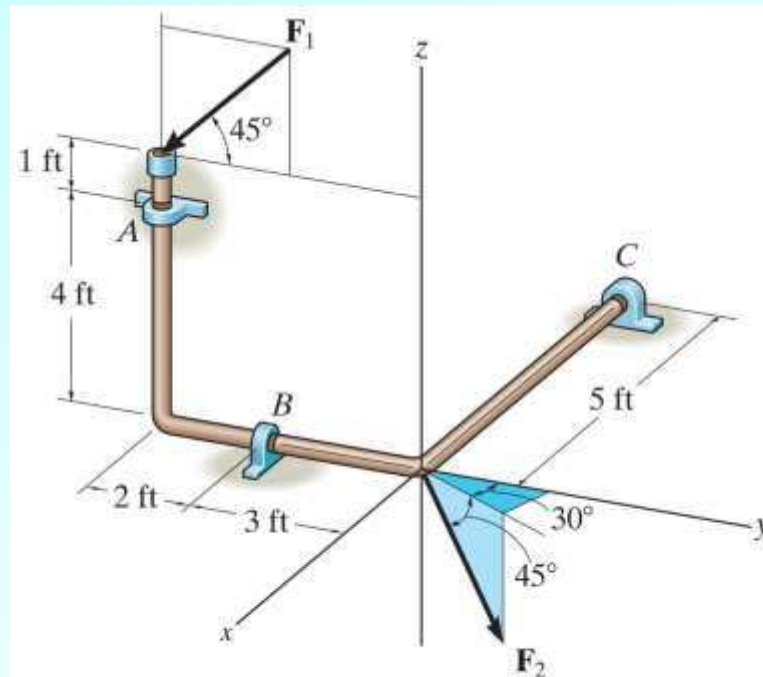

Figure: 05_P079-080

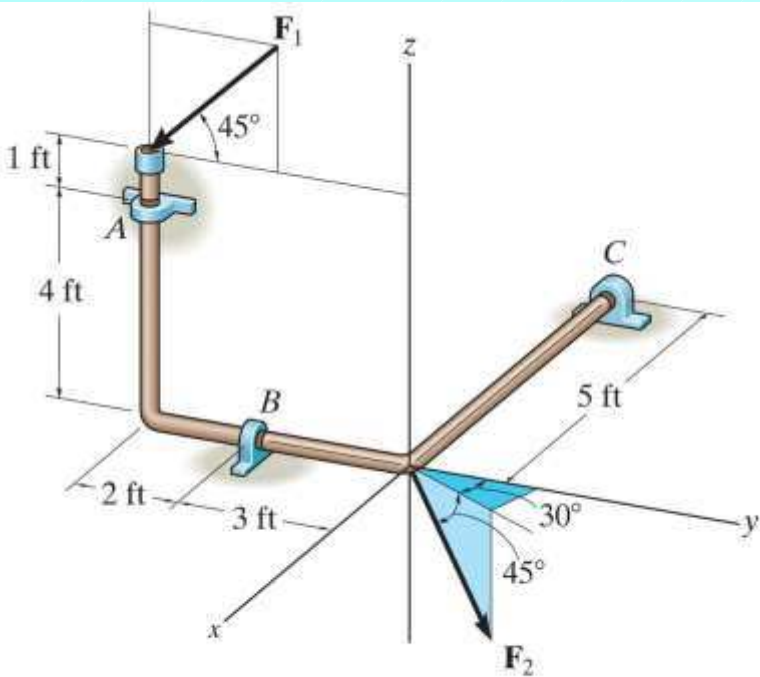
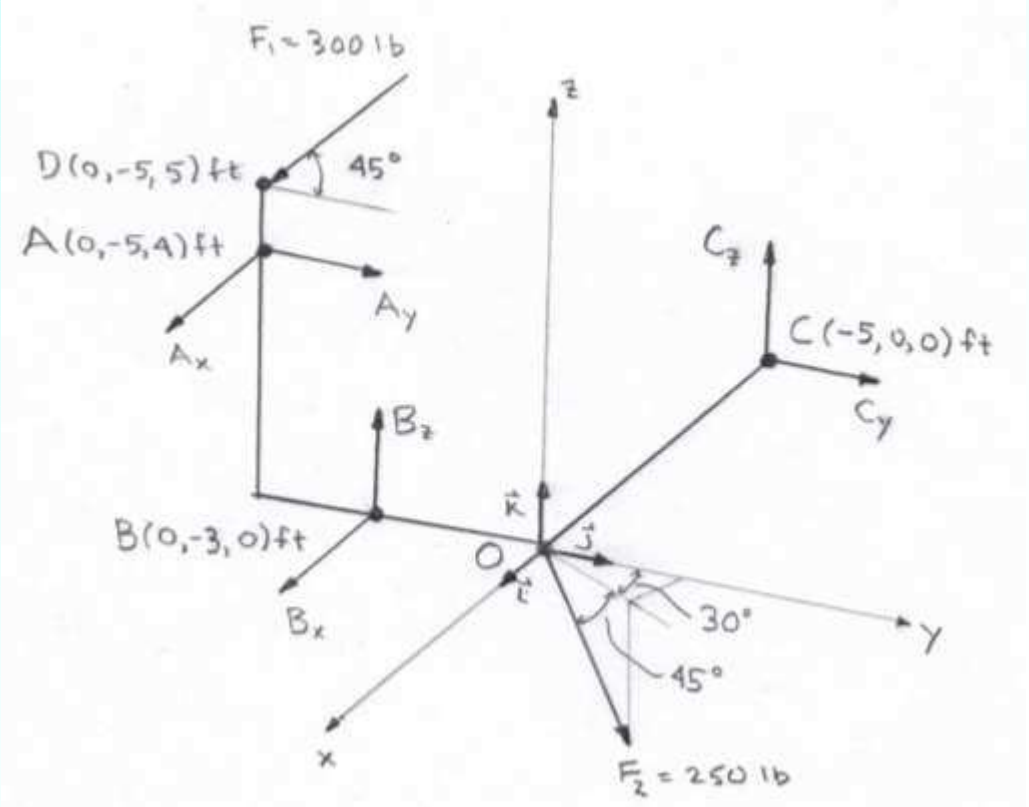
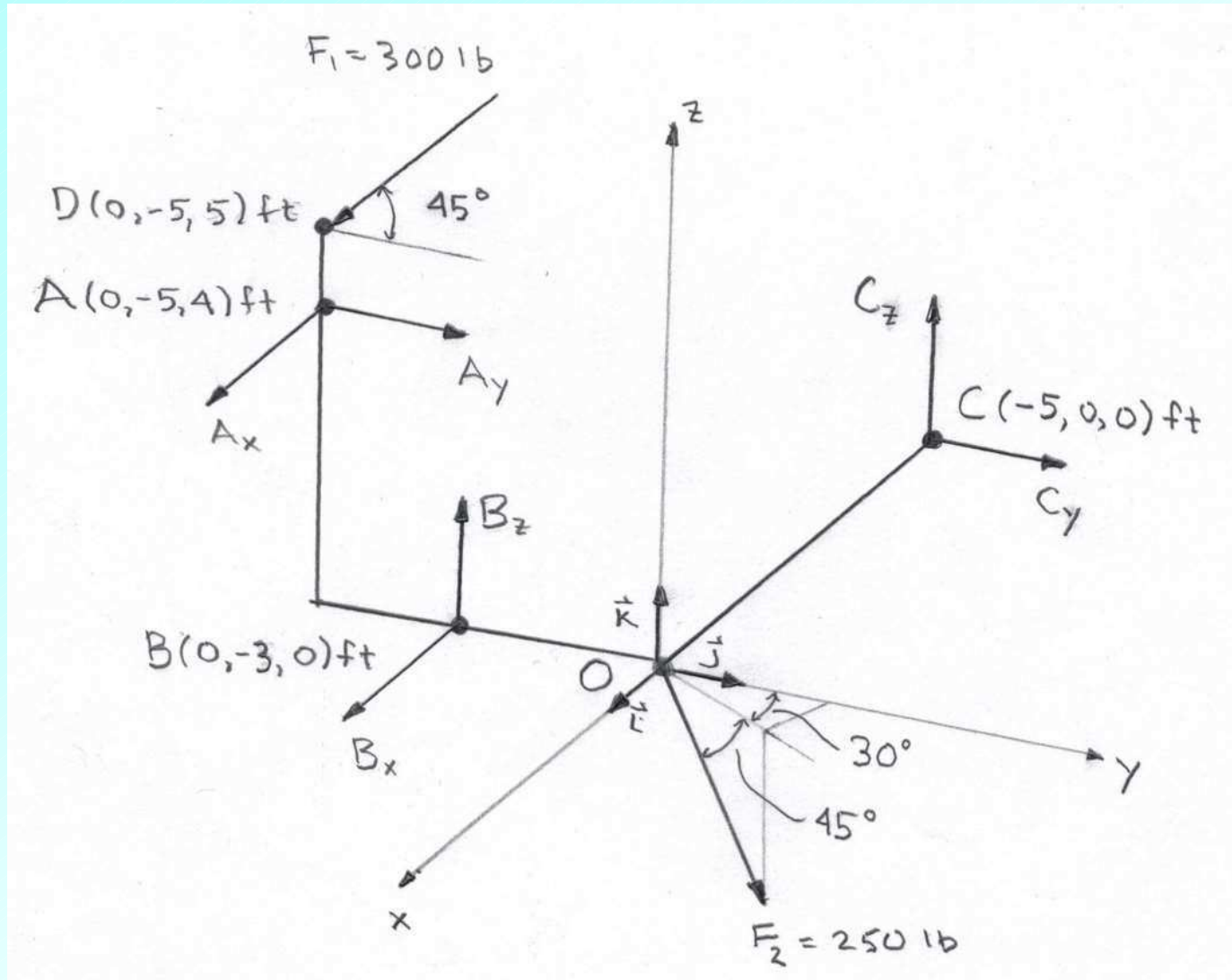

Figure: 05_P079-080

Copyright © 2011 Pearson Education, publishing as Prentice Hall



Free Body Diagram of Rod



Solution strategy

Write down coordinates of key points

Write down vector forces, then determine Cartesian component force equations of equilibrium

Compute vector moment equation of equilibrium at point O

Determine Cartesian component moment of equations of equilibrium

Assemble equations and solve them (6 equations in 6 unknowns)

Unknowns: $A_x, A_y, B_x, B_z, C_y, C_z$

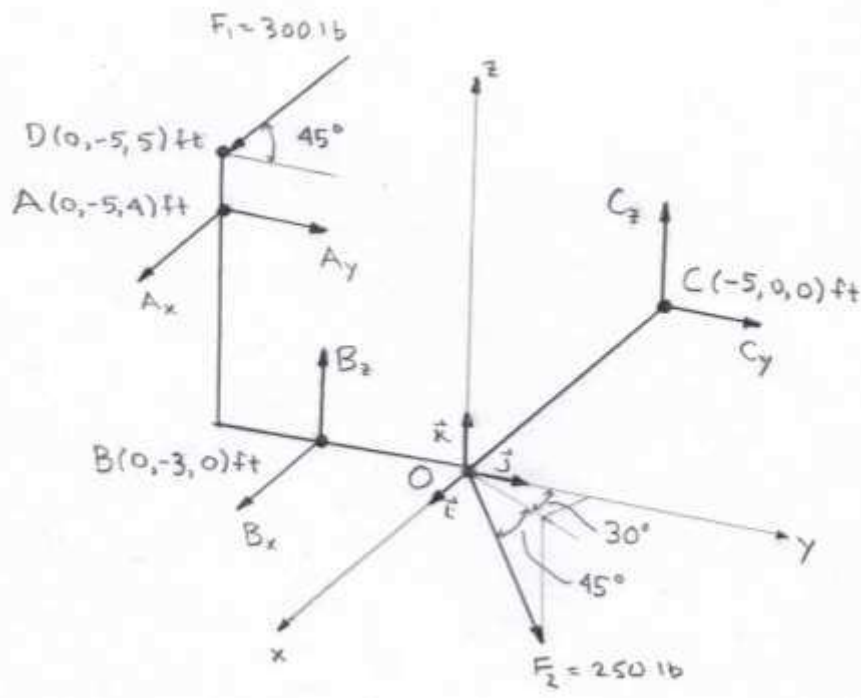

Coordinates

$$A(0, -5, 4)$$

$$B(0, -3, 0)$$

$$C(-5, 0, 0)$$

$$D(0, -5, 5)$$

Forces (suppressing units)

$$\vec{F}_A = A_x \vec{i} + A_y \vec{j}$$

$$\vec{F}_B = B_x \vec{i} + B_z \vec{k}$$

$$\vec{F}_C = C_y \vec{j} + C_z \vec{k}$$

$$\vec{F}_1 = 300(-\cos 45^\circ \vec{j} - \sin 45^\circ \vec{k})$$

$$\vec{F}_2 = 250(\cos 45^\circ \sin 30^\circ \vec{i} + \cos 45^\circ \cos 30^\circ \vec{j} - \sin 45^\circ \vec{k})$$

Cartesian component force equations of equilibrium

$$\sum F_x = 0: \quad A_x + B_x + 250 \cos 45^\circ \sin 30^\circ = 0$$

$$\sum F_y = 0: \quad A_y + C_y - 300 \cos 45^\circ + 250 \cos 45^\circ \cos 30^\circ = 0$$

$$\sum F_z = 0: \quad B_z + C_z - 300 \sin 45^\circ - 250 \sin 45^\circ = 0$$

Vector moment equation of equilibrium at point O

(\vec{F}_2 does not contribute)

$$(\vec{M}_R)_O = \sum \vec{M} + \sum \vec{r} \times \vec{F} = 0 + \vec{r}_{OA} \times \vec{F}_A + \vec{r}_{OB} \times \vec{F}_B + \vec{r}_{OC} \times \vec{F}_C + \vec{r}_{OD} \times \vec{F}_1$$

$$= \begin{vmatrix} \vec{i} & \vec{j} & \vec{k} \\ 0 & -5 & 4 \\ A_x & A_y & 0 \end{vmatrix} + \begin{vmatrix} \vec{i} & \vec{j} & \vec{k} \\ 0 & -3 & 0 \\ B_x & 0 & B_z \end{vmatrix} + \begin{vmatrix} \vec{i} & \vec{j} & \vec{k} \\ -5 & 0 & 0 \\ 0 & C_y & C_z \end{vmatrix} +$$

$$\begin{vmatrix} \vec{i} & \vec{j} & \vec{k} \\ 0 & -5 & 5 \\ 0 & -300 \cos 45^\circ & -300 \sin 45^\circ \end{vmatrix} = 0$$

Cartesian component moment equations of equilibrium

(Exercise: Verify these equations)

$$\sum M_x = 0: \quad -4A_y - 3B_z + 1500 \sin 45^\circ + 1500 \cos 45^\circ = 0$$

$$\sum M_y = 0: \quad 4A_x + 5C_z = 0$$

$$\sum M_z = 0: \quad 5A_x + 3B_x - 5C_y = 0$$

Cartesian component equations of equilibrium

$$A_x + B_x = -250 \cos 45^\circ \sin 30^\circ$$

$$A_y + C_y = \cos 45^\circ (300 - 250 \cos 30^\circ)$$

$$B_z + C_z = 550 \sin 45^\circ$$

$$4A_y + 3B_z = 1500(\sin 45^\circ + \cos 45^\circ)$$

$$4A_x + 5C_z = 0$$

$$5A_x + 3B_x - 5C_y = 0$$

Solution of the system of equations

$$A_x = 633 \text{ lb}$$

$$A_y = -141 \text{ lb}$$

$$B_x = -721 \text{ lb}$$

$$B_z = 895 \text{ lb}$$

$$C_y = 200 \text{ lb}$$

$$C_z = -506 \text{ lb}$$

Solving the system using the reduced row echelon form program $\text{rref}([M])$ on a TI graphing calculator, where $[M]$ is the 6×7 matrix

$$[M] = \begin{bmatrix} 1 & 0 & 1 & 0 & 0 & 0 & -250 \cos 45^\circ \sin 30^\circ \\ 0 & 1 & 0 & 0 & 1 & 0 & \cos 45^\circ (300 - 250 \cos 30^\circ) \\ 0 & 0 & 0 & 1 & 0 & 1 & 550 \sin 45^\circ \\ 0 & 4 & 0 & 3 & 0 & 0 & 1500(\sin 45^\circ + \cos 45^\circ) \\ 4 & 0 & 0 & 0 & 0 & 5 & 0 \\ 5 & 0 & 3 & 0 & -5 & 0 & 0 \end{bmatrix}$$

$$\text{rref}[M] = \begin{bmatrix} 1 & 0 & 0 & 0 & 0 & 0 & A_x = 632.9 \\ 0 & 1 & 0 & 0 & 0 & 0 & A_y = -141.1 \\ 0 & 0 & 1 & 0 & 0 & 0 & B_x = -721.3 \\ 0 & 0 & 0 & 1 & 0 & 0 & B_z = 895.2 \\ 0 & 0 & 0 & 0 & 1 & 0 & C_y = 200.1 \\ 0 & 0 & 0 & 0 & 0 & 1 & C_z = -506.3 \end{bmatrix}$$