

PHYS 170 Section 101  
Lecture 13  
October 3, 2018

# OCT 3—ANNOUNCEMENTS

- No tutorials next week
- Review sessions in regularly scheduled tutorial slots (same times, same places), Tuesday, Oct 9
  - General review of key concepts / techniques
  - Go over one past midterm
  - Hope to leave some time for your specific questions
  - Will do my best to provide same information in all four sessions

# Information about midterm exam

## PHYSICS 170 MECHANICS 1: SECTION 101 (2018 W1) INFORMATION ABOUT EXAMS

### **October Exam**

The October Exam will be written **2:00 PM to 2:50 PM, Friday, October 12**, in our usual lecture hall, Life Building 2201.

The exam is worth 20 marks out of 100 marks for the course.

The exam will consist of 2 questions based on text Chapters 1, 2, 3 and 4.

### **Graphing Calculator**

You may bring a graphing calculator to any and all of the three exams.

### **Information Sheet**

You may bring one *handwritten* (on both sides if you like) 8 ½ in by 11 in (216 mm by 279 mm) Information Sheet to any and all of the three exams.

You must prepare your own Information Sheet.

Your Information Sheet must not contain any reduced or printed material or any sample problems or solutions to sample problems.

In order for your exam to be marked, you must sign your Information Sheet and hand it in with your exam booklet. Your Information Sheets will *not* be returned.

# Lecture Outline/Learning Goals

- Support/reaction table and free-body diagrams
- Equations of equilibrium redux
- Sample three-dimensional equilibrium problem #1

**TABLE 5-2 Supports for Rigid Bodies Subjected to Three-Dimensional Force Systems**









Types of Connection	Reaction	Number of Unknowns
<p>(1)</p>  <p>cable</p>		<p>One unknown. The reaction is a force which acts away from the member in the known direction of the cable.</p>
<p>(2)</p>  <p>smooth surface support</p>		<p>One unknown. The reaction is a force which acts perpendicular to the surface at the point of contact.</p>
<p>(3)</p>  <p>roller</p>		<p>One unknown. The reaction is a force which acts perpendicular to the surface at the point of contact.</p>

TABLE 5-2 Supports for Rigid Bodies Subjected to Three-Dimensional Force Systems

Types of Connection	Reaction	Number of Unknowns
<p>(4)</p>  <p>ball and socket</p>		<p>Three unknowns. The reactions are three rectangular force components.</p>
<p>(5)</p>  <p>single journal bearing</p>		<p>Four unknowns. The reactions are two force and two couple-moment components which act perpendicular to the shaft. Note: The couple moments are <i>generally not applied</i> if the body is supported elsewhere. See the examples.</p>

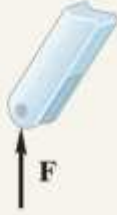
by a support that resists moments about the  $x$  and  $z$  axes of the bearing (e.g. by another bearing)

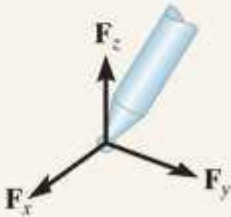
TABLE 5-2 Continued

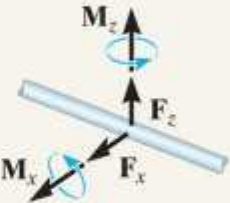







Types of Connection	Reaction	Number of Unknowns
<p>(6)</p>  <p>single journal bearing with square shaft</p>		<p>Five unknowns. The reactions are two force and three couple-moment components. <i>Note:</i> The couple moments are generally not applied if the body is supported elsewhere. See the examples.</p>
<p>(7)</p>  <p>single thrust bearing</p>		<p>Five unknowns. The reactions are three force and two couple-moment components. <i>Note:</i> The couple moments are generally not applied if the body is supported elsewhere. See the examples.</p>
<p>(8)</p>  <p>single smooth pin</p>		<p>Five unknowns. The reactions are three force and two couple-moment components. <i>Note:</i> The couple moments are generally not applied if the body is supported elsewhere. See the examples.</p>

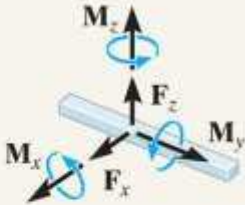

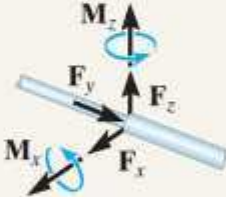
TABLE 5-2 Continued

Types of Connection	Reaction	Number of Unknowns
<p>(9)</p>  <p>single hinge</p>		<p>Five unknowns. The reactions are three force and two couple-moment components. <i>Note:</i> The couple moments are generally not applied if the body is supported elsewhere. See the examples.</p>
<p>(10)</p>  <p>fixed support</p>		<p>Six unknowns. The reactions are three force and three couple-moment components.</p>

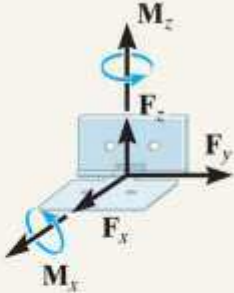
# Drawing Free Body Diagrams

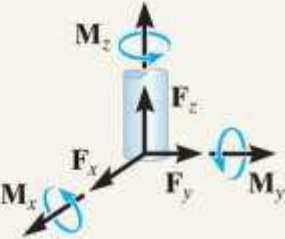
- Make diagram large, not least so that it can be completely and clearly labeled
- Draw a schematic shape of the body: a “stick” figure will generally suffice
- Show all forces and couple moments acting on the body
- Establish the origin of the  $x$ ,  $y$ , and  $z$  axes at a convenient point and orient the axes so that they are parallel to as many of the external forces and moments as possible. Note that in problem-solving these axes will typically be given/suggested in the figure for the problem
- Label all forces and couple moments (or components thereof) and specify their directions. In general, show all the *unknown* components having a *positive sense* along the  $x$ ,  $y$ ,  $z$  axes.

# Drawing Free Body Diagrams

- Draw and label the usual Cartesian unit vectors  $\vec{i}$ ,  $\vec{j}$ ,  $\vec{k}$  emanating from the origin (i.e. with tails at the origin, and pointing in the correct directions +x, +y, +z respectively)
- Label all the key points on the free body diagram, such as points of support, with their Cartesian coordinates, using the  $P(x,y,z)$  notation
- Use a straightedge for all straight lines, including depictions of vectors and moments. Indicate rotational sense of moments (assumed if necessary) using “rotating arrow” symbols as in text
- The weight of a body is an external force and its effect is represented by a single resultant force acting through the body’s center of gravity,  $G$

# Free bodies in the wild



How many UBC engineering students  
can you fit in a VW Beetle suspended  
underneath the Lions Gate Bridge?

*Not enough!*

(Ubysey editorial cartoon, early 1980's)



## 5.6 Equations of Equilibrium

### Vector equations of equilibrium

As discussed previously, the vector conditions for equilibrium of a rigid body are

$$\begin{aligned}\sum \vec{F} &= 0 \\ \sum \vec{M}_O &= 0\end{aligned}$$

where  $\sum \vec{F}$  is the vector sum of all the forces acting on the body and  $\sum \vec{M}_O$  is the sum of any couple moments and the moments of all the forces about **any** point  $O$ .

## Scalar equations of equilibrium

In Cartesian vector form, the equations of equilibrium become

$$\sum \vec{F} = \sum F_x \vec{i} + \sum F_y \vec{j} + \sum F_z \vec{k} = 0$$

$$\sum M_O = \sum M_x \vec{i} + \sum M_y \vec{j} + \sum M_z \vec{k} = 0$$

The  $\vec{i}$ ,  $\vec{j}$ , and  $\vec{k}$  components are independent of one another, so these are equivalent to the six scalar equations:

$$\begin{array}{lll} \sum F_x = 0 & \sum F_y = 0 & \sum F_z = 0 \\ \sum M_x = 0 & \sum M_y = 0 & \sum M_z = 0 \end{array}$$

These equations can be used to solve for at most six unknowns shown on the free body diagram.

## Problem 5-72 (page 255, 12<sup>th</sup> edition)

The pipe assembly is subjected to a force and couple moment as shown and is held in equilibrium by smooth journal bearings  $A$ ,  $B$ , and  $C$ . The bearings are in proper alignment and only exert force reactions on the pipe assembly. The weight of the pipe assembly can be neglected.

(1) Determine the Cartesian components of these force reactions.

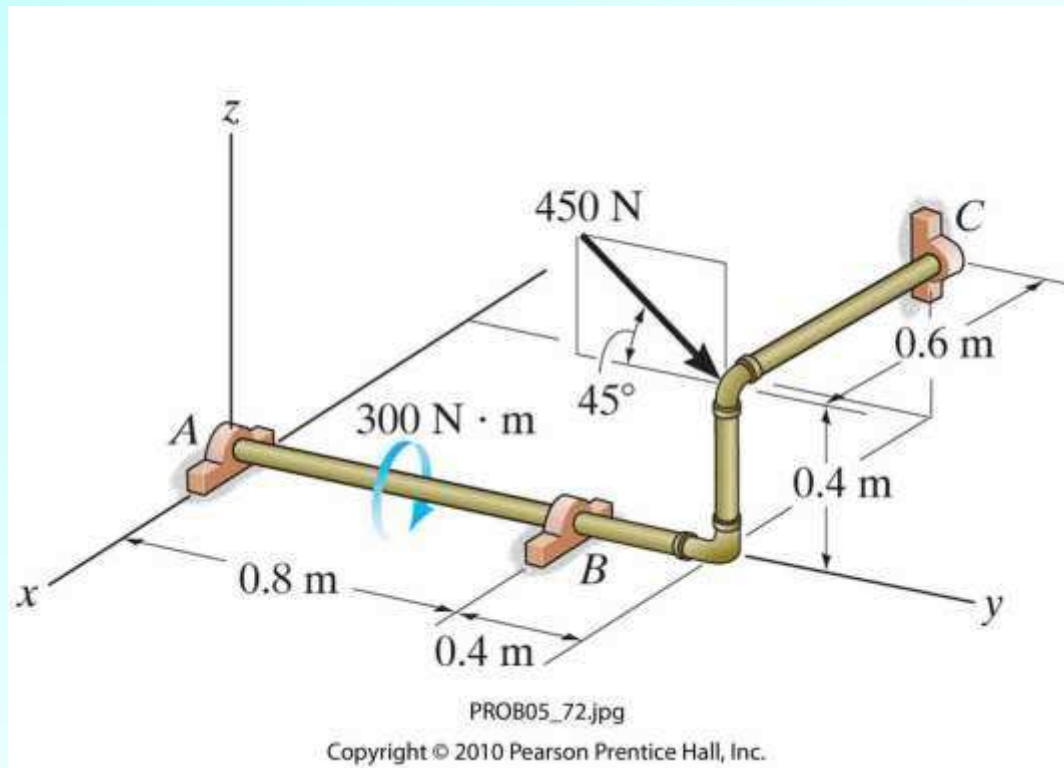

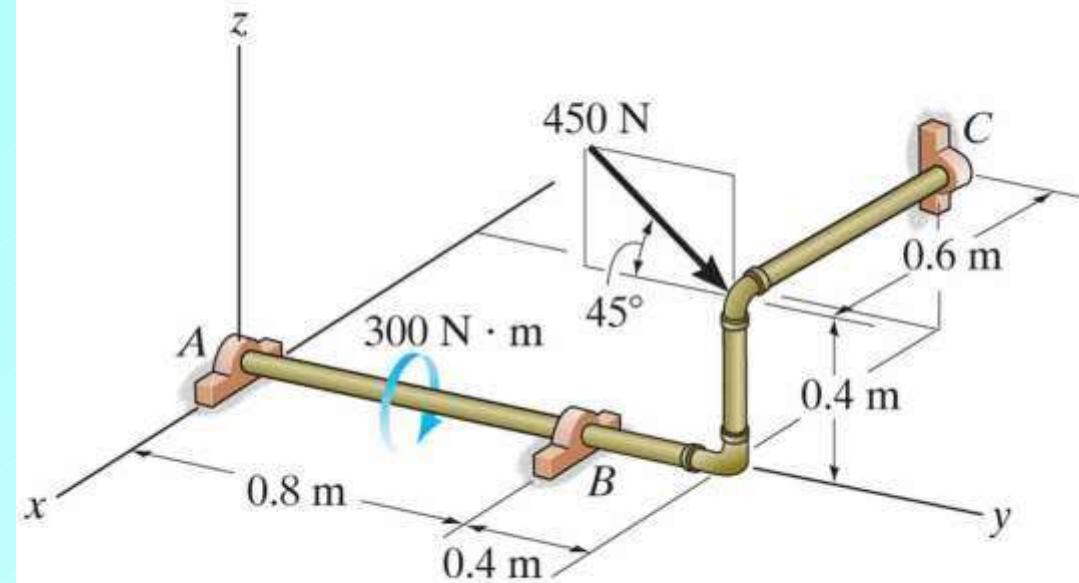

PROB05\_72.jpg

Copyright © 2010 Pearson Prentice Hall, Inc.

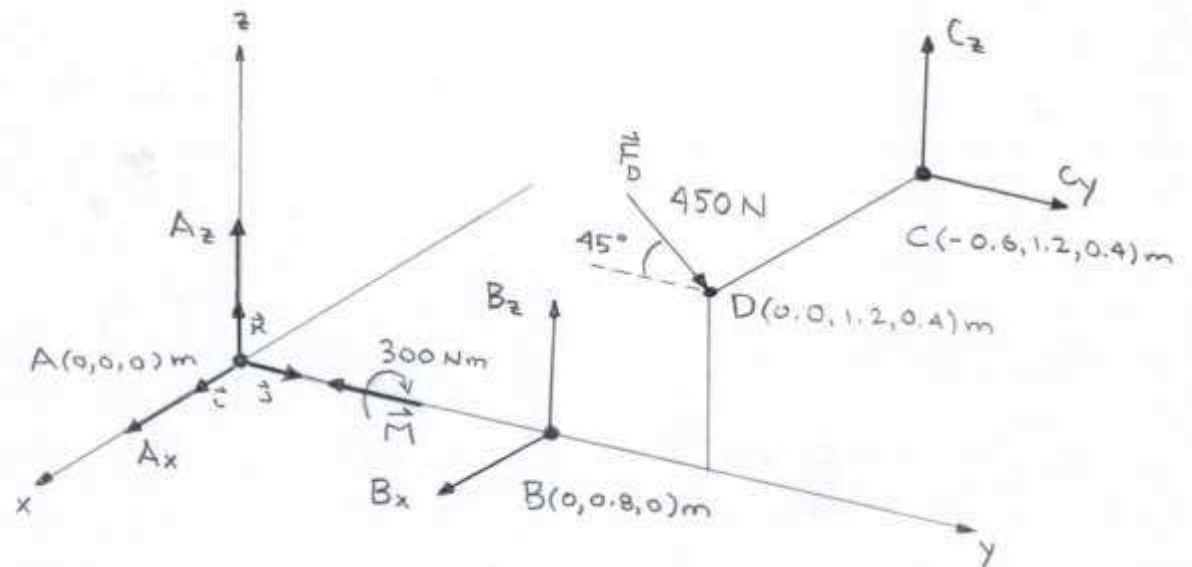



# Free Body Diagram of Pipe Assembly

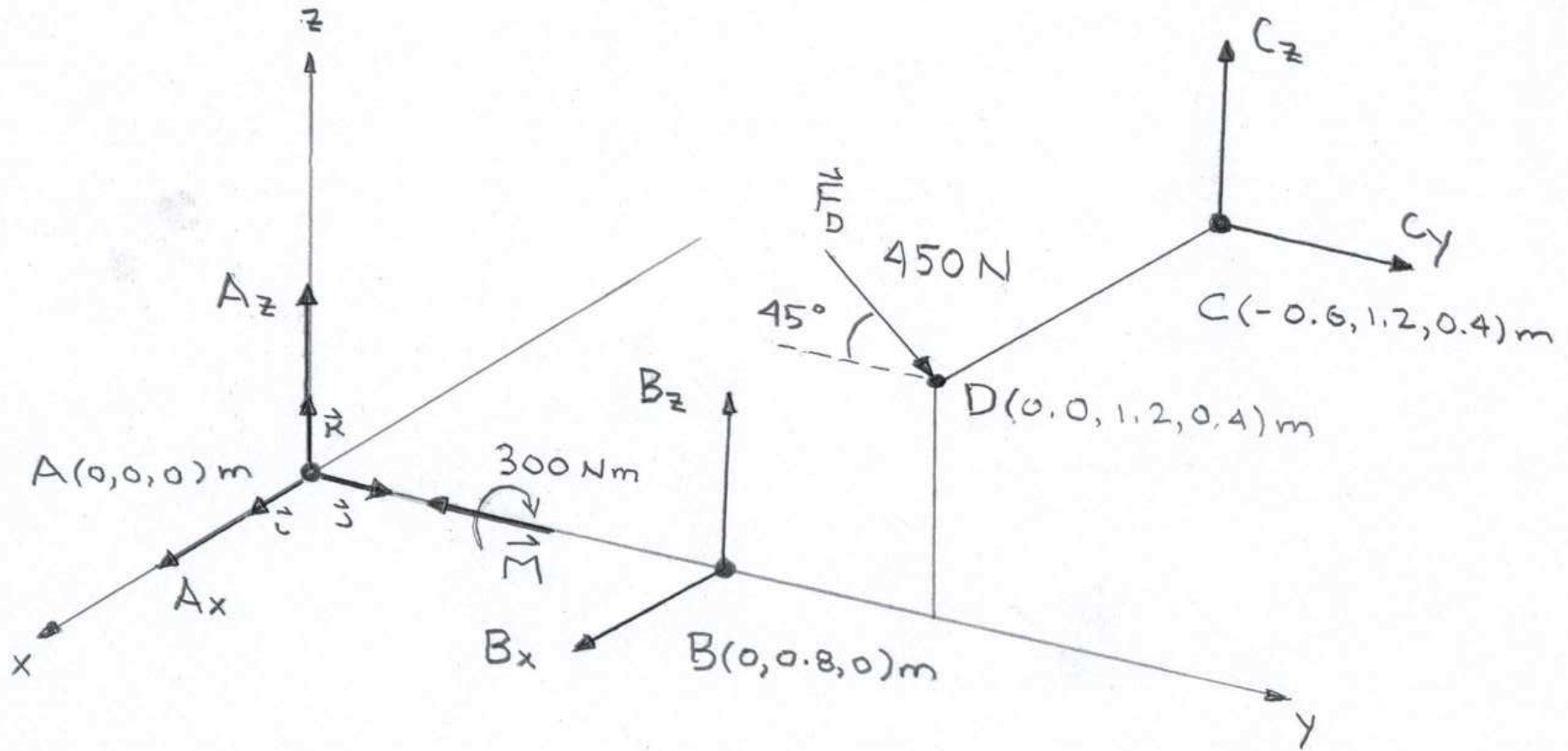

## Coordinates (suppressing units)

$$A(0, 0, 0)$$

$$B(0, 0.8, 0)$$

$$C(-0.6, 1.2, 0.4)$$

$$D(0.0, 1.2, 0.4)$$

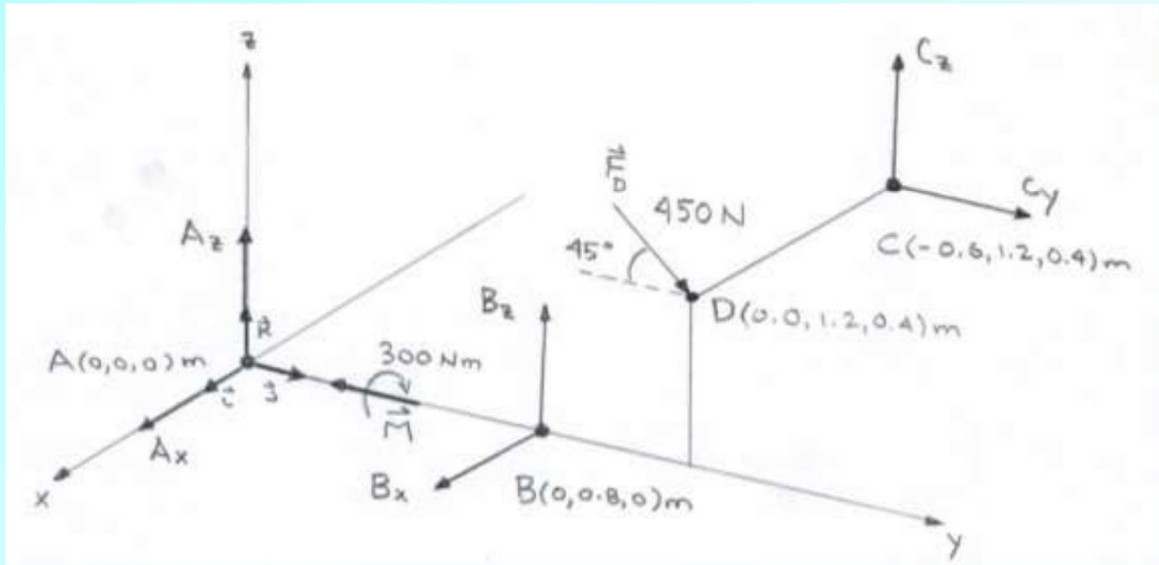

## Forces and couple moment (suppressing units)

Note that there are 6 unknown reaction components, which is the maximum for which we can solve using the equations of equilibrium.

$$\vec{F}_A = A_x \vec{i} + A_z \vec{k}$$

$$\vec{F}_B = B_x \vec{i} + B_z \vec{k}$$

$$\vec{F}_C = C_y \vec{j} + C_z \vec{k}$$

$$\vec{F}_D = 450 \cos 45^\circ \vec{j} - 450 \sin 45^\circ \vec{k}$$

$$\vec{M} = -300 \vec{j}$$

## Cartesian component force equations of equilibrium

$$\sum F_x = 0: \quad A_x + B_x = 0$$

$$\sum F_y = 0: \quad C_y + 450 \cos 45^\circ = 0$$

$$\sum F_z = 0: \quad A_z + B_z + C_z - 450 \sin 45^\circ = 0$$

Vector moment equation of equilibrium at point A. Note that force  $\vec{F}_A$  does not contribute.

$$(\vec{M}_R)_A = \sum \vec{M} + \sum (\vec{r} \times \vec{F}) = 0$$

$$-300\vec{j} + \begin{vmatrix} \vec{i} & \vec{j} & \vec{k} \\ 0 & 0.8 & 0 \\ B_x & 0 & B_z \end{vmatrix} + \begin{vmatrix} \vec{i} & \vec{j} & \vec{k} \\ -0.6 & 1.2 & 0.4 \\ 0 & C_y & C_z \end{vmatrix} + \begin{vmatrix} \vec{i} & \vec{j} & \vec{k} \\ 0 & 1.2 & 0.4 \\ 0 & 450 \cos 45^\circ & -450 \sin 45^\circ \end{vmatrix} = 0$$

## Cartesian component moment equations of equilibrium

$$\sum M_x = 0: \quad 0.8B_z + 1.2C_z - 0.4C_y - 1.2(450)\sin 45^\circ - 0.4(450)\cos 45^\circ = 0$$

$$\sum M_y = 0: \quad 0.6C_z - 300 = 0$$

$$\sum M_z = 0: \quad -0.8B_x - 0.6C_y = 0$$

## Cartesian component equations of equilibrium

$$A_x + B_x = 0$$

$$C_y = -450\cos 45^\circ$$

$$A_z + B_z + C_z = 450\sin 45^\circ$$

$$0.8B_z + 1.2C_z - 0.4C_y = 1.2(450)\sin 45^\circ + 0.4(450)\cos 45^\circ$$

$$0.6C_z = 300$$

$$0.8B_x + 0.6C_y = 0$$

Solve by substitution: e.g. solve in succession for  $C_y$ ,  $C_z$ ,  $B_z$ ,  $B_x$ ,  $A_x$ ,  $A_z$

(restoring units)

$$A_x = -239 \text{ N}$$

$$A_z = 90.9 \text{ N}$$

$$B_x = 239 \text{ N}$$

$$B_z = -273 \text{ N}$$

$$C_y = -318 \text{ N}$$

$$C_z = 500 \text{ N}$$

The negative signs indicate that the forces are directed in the sense opposite to what was assumed, that is, along the negative coordinate axes.